

Figure A

Figure B

Installing Bedbridge™ Three Leg Kit to Wood Side Rails with Slat Rail

Parts Required: Kit for Full, Queen, King or Cal King

Tools Required: Screwdriver, tape measure, pencil

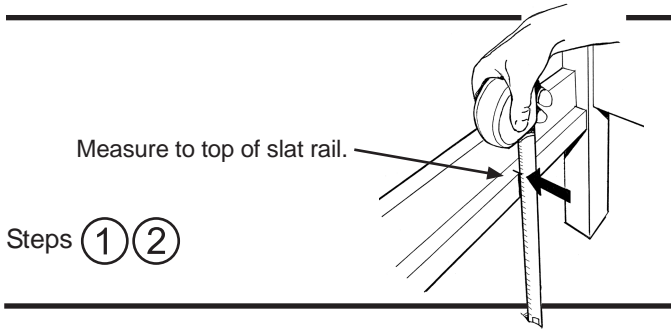

- ① Measure from floor to the top of the slat rail. Find this measurement on the chart below. Chart indicates proper Leg/Glide combination to use.
- ② Attach the appropriate Legs and Glides together.

LEG LENGTH CHART

6" - 9.5"	9.5"-12.5"	12.5"-14.5"	14.5"-16.5"	16.5"-18.5"
Short Leg Short Glide	Medium Leg Short Glide	Medium Leg Long Glide	Long Leg Short Glide	Long Leg Short Glide

Example: 10 1/2" measurement to top of slat rail would use Medium Leg and Short Glide.

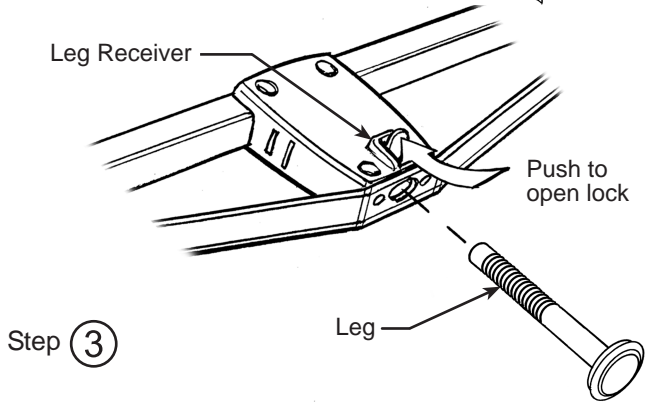

- ③ Insert the Leg/Glide combination into the Leg Receiver on the beam. The lock on the Receiver must be opened by pushing lock lever as shown. Insert the Leg as far as possible into Receiver.

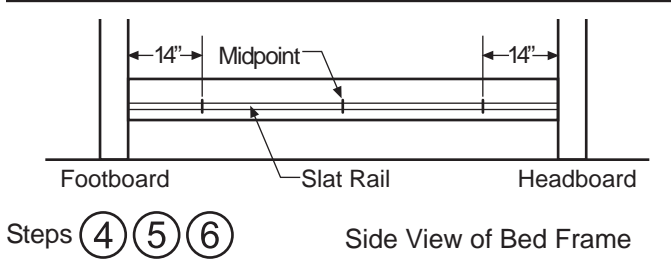

- ④ Measure and mark 14" from Headboard along the slat rail.
- ⑤ Measure and mark 14" from Footboard along the slat rail.
- ⑥ Mark the location midway between the Headboard and Footboard on the slat rail.

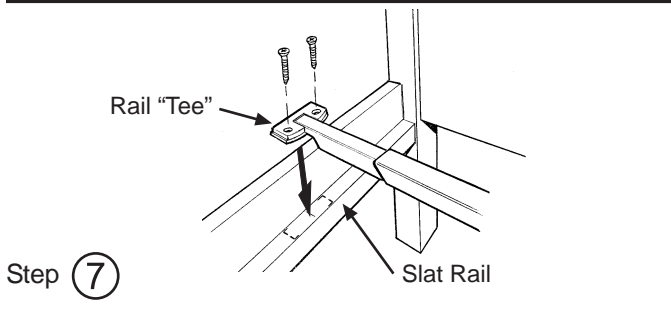

- ⑦ Arrange the 3 Bedbridge™ beams in your kit as shown in the bed frame Figure B at top of page.

Set both "TEE" ends onto slat rails, spanning from side rail to side rail. Extend slide ends of Bedbridge™ as required. Position "TEES" on slat rails, centering a "TEE" on each mark. Attach with wood screws provided.

Repeat to attach all beams to slat rails.

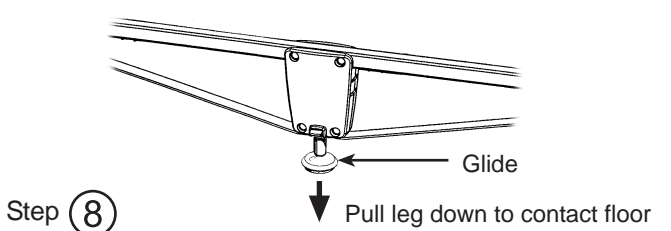

- ⑧ Pull Leg down until it contacts floor. The mechanism will automatically lock the Leg in position. Repeat with each leg. Note: To raise the Leg after it is extended, push lock lever.
- ⑨ Foundation and mattress can now be installed onto the Bedbridge Bed Support System.

IMPORTANT:

The Legs must be perpendicular to the floor. Use care when moving the bed, cleaning or placing items under the bed.